

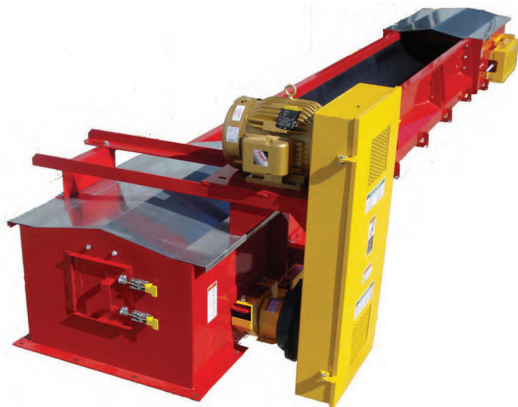

OUR NAME. OUR REPUTATION. O'MARA.

RB SERIES – ROUND BOTTOM BELT CONVEYORS

Stationary enclosed round bottom, half tube belt conveyors for transfer of bulk materials at inclines up to 30 degrees. Specifically designed to convey small, free flowing materials such as seed, grain, or feed where the round bottom trough design contains the product and helps to prevent leakage.



- ✓ Numerous designs, lengths, available to meet the project scope.
- ✓ Belt widths available in 8", 10", 12", 16", 20", 24", and 26" with stainless steel belt lacing.
- ✓ Gear reduction drives sized and specified per application.
- ✓ Push-style, guarded screw take-ups standard.
- ✓ 1.9" dia. Galvanized return rollers.
- ✓ Formed and welded 12 gauge frames.
- ✓ Standard 10 gauge drive and take-up terminals.
- ✓ Standard powder coat finish, your choice of color.

STANDARD FEATURES

- ✓ **CONVEYOR FRAMES:** Enclosed frame design with drive and take-up terminals fabricated from 10 gauge sheet steel, intermediate sections are 12 gauge sheet steel. Welded construction with formed radius, round bottom trough and 1.9" diameter galvanized return idlers spaced 60" O.C. All return idlers are double punched for ideal belt tracking. All bottom flanges are turned in at 45° and all spreader angles are inverted so as not to create any ledges that may catch product.
- ✓ **BELTING TYPES:** Minimum PVC 150#. Smooth top, crescent top, rough top, and pattern top belts are available depending on the application with stainless steel mechanical belt lacing.
- ✓ **POWER/DRIVES:** 208-230/460 3 phase and 230 volt single phase TEFC motors. Explosion proof, wash down, and corrosion resistant available upon request. Gear reduction shaft mounted, right angle, and right angle/chain final drives are available.



O'MARA AG & EQUIPMENT SERVICES

1626 Delaware Ave.
Des Moines, IA 50317
(515) 989-2094
www.omara-ag.com

ROBIN O'MARA,

President / (515) 321-5267
romara60@msn.com

BRUCE COCKRAM,

Outside Sales / (515) 681-2160
Bruce.Cockram@omara-ag.com

STANDARD FEATURES (CONTINUED)

- ✓ **PULLEYS:** Crowned and vulcanized, rough top lagged head pulleys are standard in 6", 8", 10, 12", 16", 18", and 24" diameters, depending on overall length of the conveyor. Crowned take-up pulleys are 4", 6", 8", or 12" diameter. Standard snub rollers are 4" or 6" diameter.
- ✓ **GUARDING:** Every conveyor is shipped with all of its moving parts guarded, take-ups, and drives as an integrated standard feature, not as an add-on.

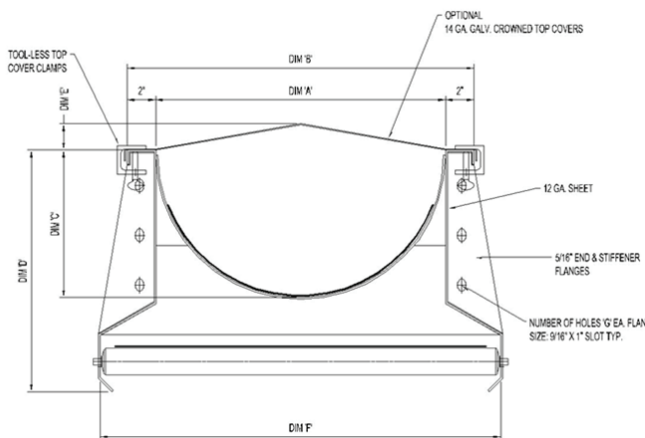

ROUND BOTTOM (RB) 100 SERIES STANDARD CROSS SECTION							
BELT WIDTH	DIM 'A'	DIM 'B'	DIM 'C'	DIM 'D'	DIM 'E'	DIM 'F'	# HOLES 'G'
8"	6-1/4"	10-1/4"	3-1/2"	9-1/2"	1/2"	10"	1
10"	8-1/4"	12-1/4"	4-1/4"	10"	3/4"	12"	1
12"	10-1/4"	14-1/4"	5-1/2"	11-1/2"	1"	11-1/2"	2
16"	14-1/4"	18-1/4"	7-1/4"	13"	1-1/4"	13"	2

ADDITIONAL OPTIONS

- ✓ Galvanized hip-roof topweather covers.
- ✓ Formed mild steel orexpanded metal,hinged bottom covers.
- ✓ Discharge chutes, linedand un-lined.
- ✓ Belt skirting: Rubber, metal, or combination or both.
- ✓ Reversing center drives.
- ✓ Belt loaders, inletboxes, and receivinghoppers.
- ✓ Inside radius and outsiderside radius bendwedges.
- ✓ Structural supports.
- ✓ Anti static black UHMW trough wear liners.
- ✓ Stainless steel construction

